

ACS VALVES

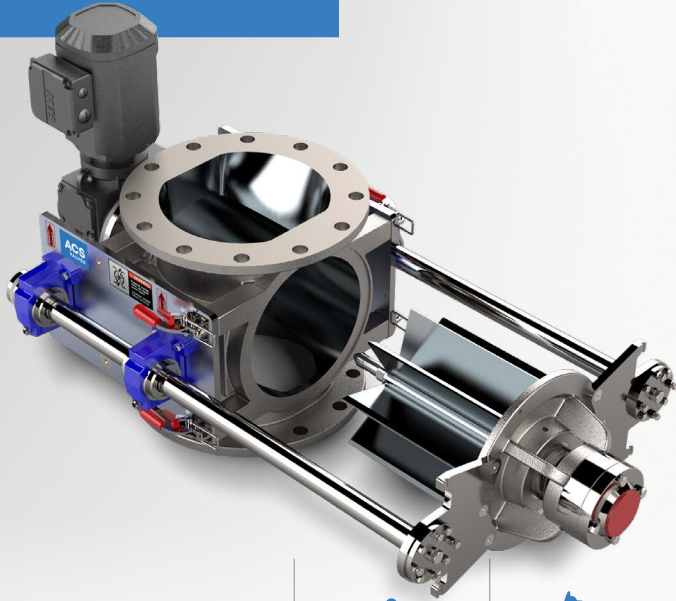

Product Specifications

MD Series

with Quick-Clean RotorRail™

Rotary Valve for Metering, Feeding and Airlock Applications

Tool-less, single-step access to rotor and internal surfaces; simplifying cleaning, validation, and inspection.

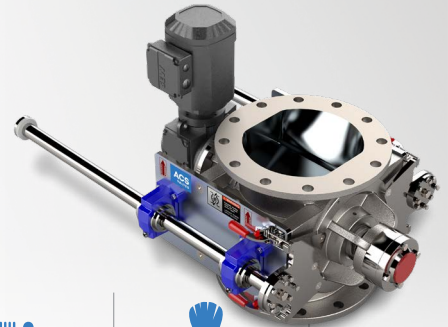

SECTOR INDUSTRIES:



Plastics



Pet Food



Construction



Food



Pharmaceutical
and Cosmetics



Chemical

FEATURES

- Tool-less, single-step access to rotor and internal surfaces; simplifying cleaning, validation, and inspection.
- RotorRail™ feature maintains rotor and endplate alignment during dis-assembly; ensures fast and accurate rotor and endplate re-alignment during re-assembly.
- Available in 7 heights, from 7 3/8"H to 23"H; and 7 flange inside diameters from 4" to 15".
- CNC-machined components and housing provide precision tolerances; eliminates axial shaft movement, extends maintenance cycles.
- Outboard bearing design protects bearings in high-temperature and high-PSIG applications; removes bearings from direct path of damaging contaminants.
- Easily manages pressure differentials up to 15 PSIG.
- Excellent performance in high-temperature applications up to 500°F.
- 8-vane rotor with beveled tips and sides.
- Direct-drive motor package.

SPECIFICATIONS:

INLET/OUTLET
FLANGE SIZES:

4 sizes from 4" to 18"

MATERIAL OF
CONSTRUCTION:

Cast Iron,
Stainless Steel

PRESSURE
DIFFERENTIAL:

Up to 15 PSIG

HIGH TEMPERATURE
RANGE:

500°F